

The Tie Down Rack is installed with Utility rack 530181.

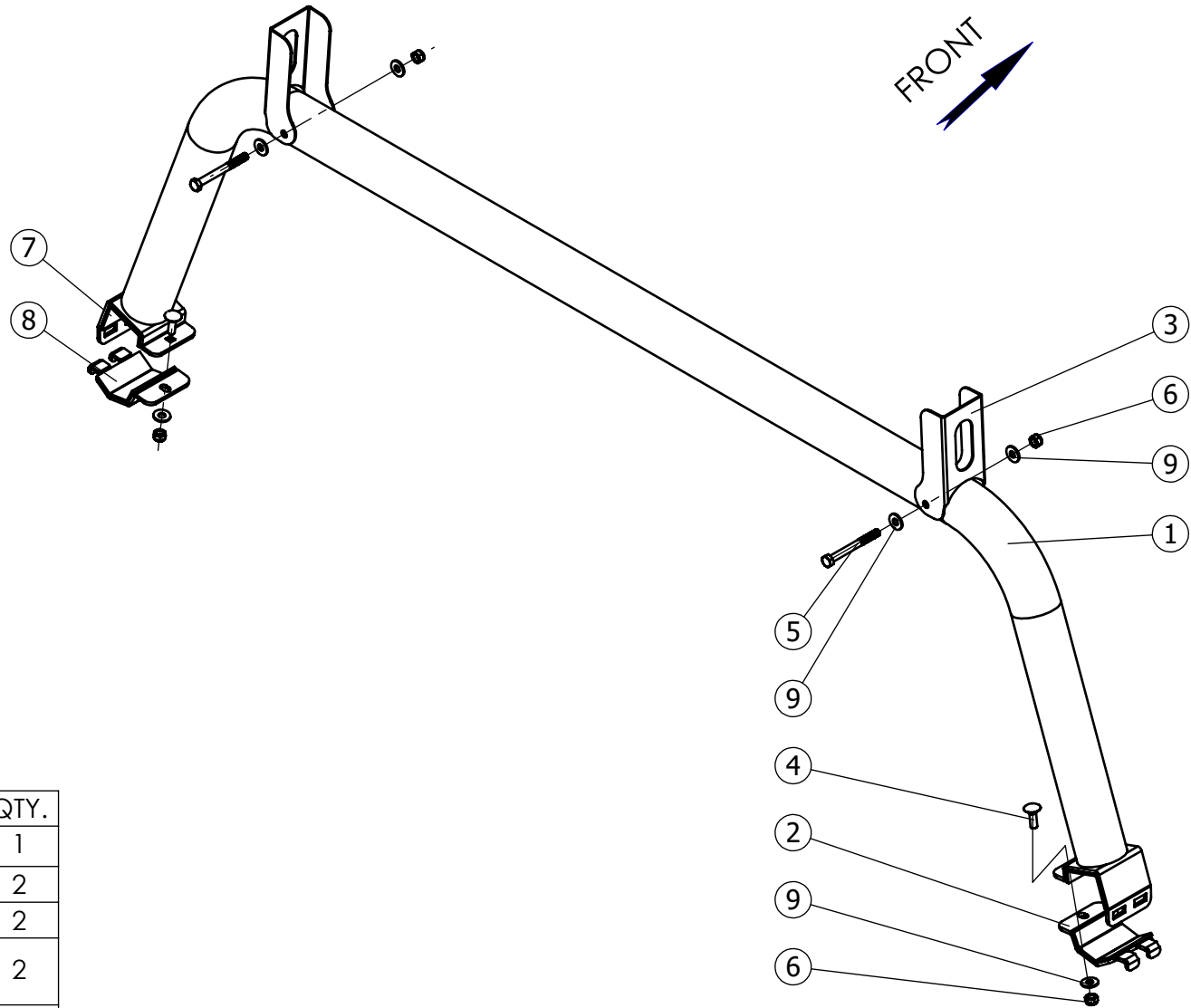

NO.	PART NUMBER	DESCRIPTION	QTY.
1	ISW54.120.000	Welded rear pipe	1
2	TYW73.050.001	Lower Bracket	2
3	DOW09.000.007	Holder	2
4	1140	Mushroom head square neck Bolt M8x30 DIN 603	2
5	1058	Hex Bolt M8x80 DIN 931	2
6	3005	Hex Nut Nylock M8 DIN 985	4
7	6940	Neoprene 120x70x4	2
8	6940	Neoprene 80x70x4	2
9	6003	Washer 8x20 DIN 125	6

	NAME	SIGN.	DATE
CHG.	Slava		08.03.17
DWN.	Slava		21.10.13
PLN.	David		08.03.17
CONFIRM	Dani		

**ASFIR LTD.**

Product Description	
Vehicle Manuf.	ISUZU
Vehicle Model	D-MAX
Vehicle Version	Double Cab
VIN	MPATFS87JHT001916
Year of Product.	2012-2017
Gear Shift	AUTOMATIC/MANUAL
Motor Model	DIESEL 2.5TD / 1.9TD
Transmission	4X4

Confidential

All rights in and to this document are property of ASFIR Ltd. and reserved to it. This document is forwarded to the recipient under the condition of and subject to the obligation of the recipient to keep the confidentiality of its contents. Copying, transfer or distribution of this document or its contents and the use of it not for the purpose intended-are strictly forbidden.

Drawing number	ISW54.100.000
Drawing description	Tie Down Rack
Catalogue number	530179
Mass, kg	10.6