

Side Steps

Mounting instructions for Toyota Hilux 2018

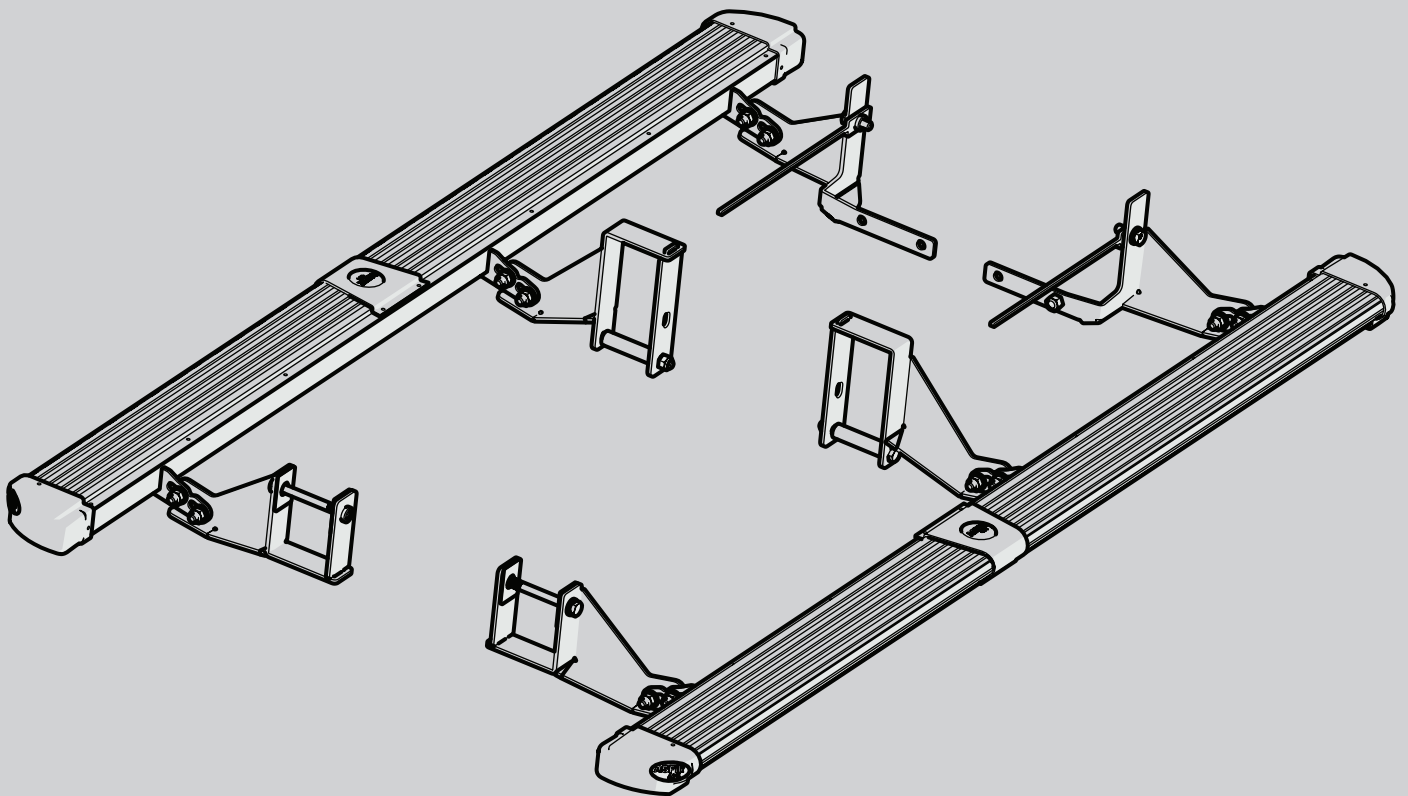

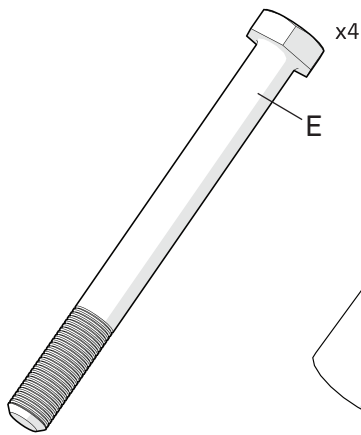
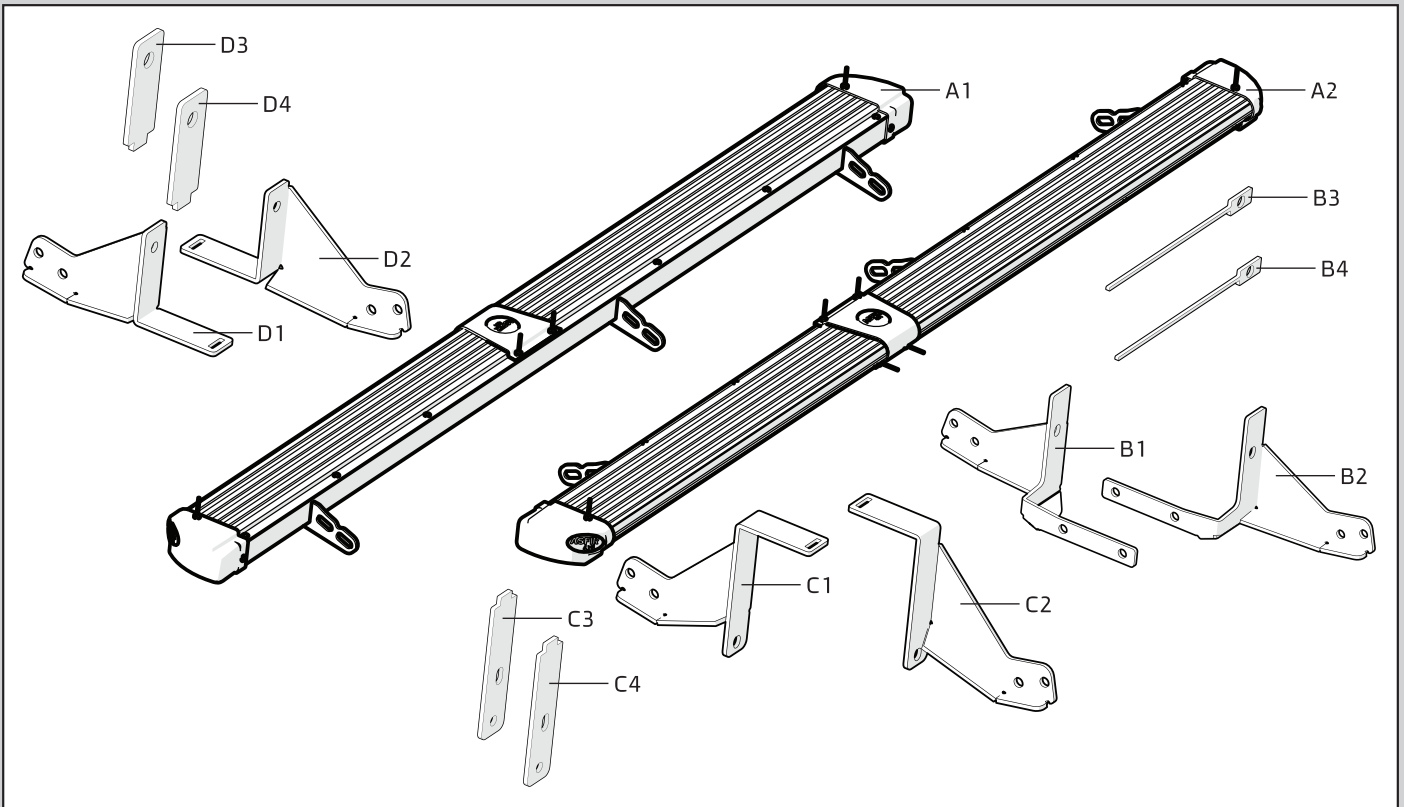

Hex Bolt M12X1.75X120

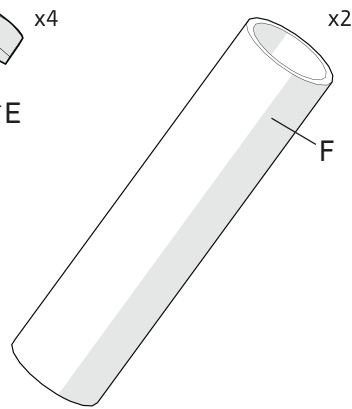

spacer

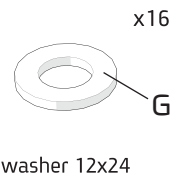

washer 12x24

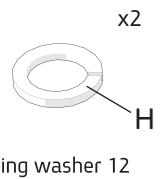

spring washer 12

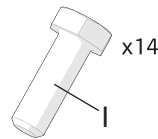

Hex Bolt M12X1.75X35

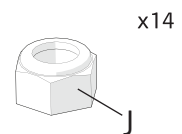

Hex Nut Nylock M12x1.75

Maximum Tightening Torques	
M12 (8.8)	85 Nm

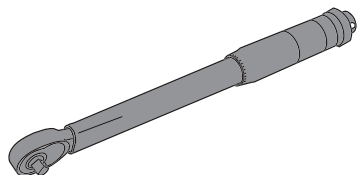

12,19

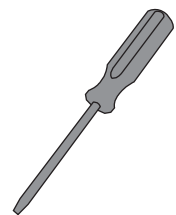
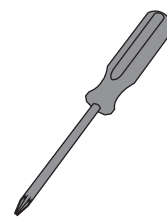

12,17,19

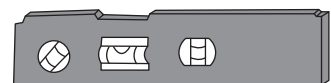



Remove bolts and dispose the original step

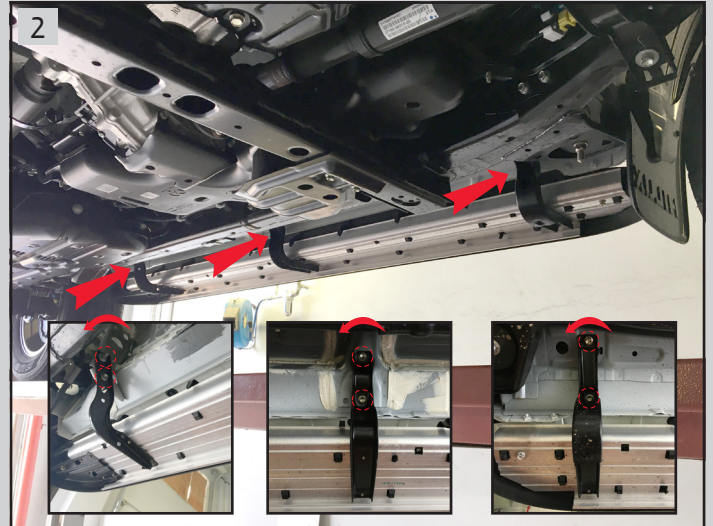

Remove bolts and dispose the original step

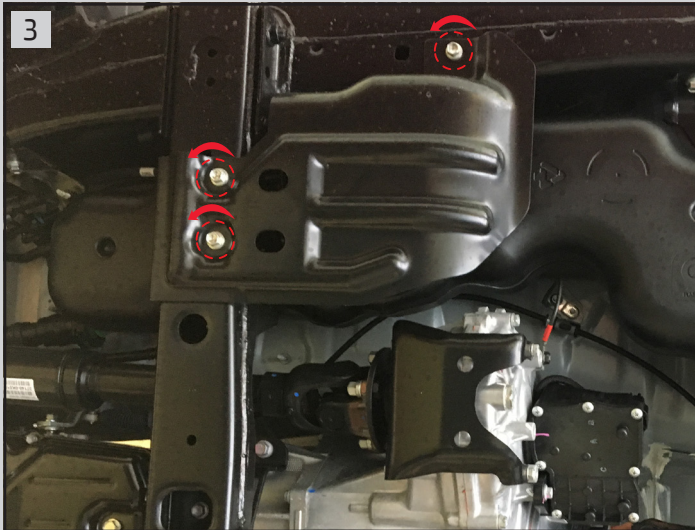

Open 3 bolts to remove the Urea Tank Skid Plate



Front left bracket (B1):
Open 2 Nuts



Remove 4 caps. 2 on right side of the vehicle.
2 on left side of the vehicle



Bend Plate (B3)



7
Place bracket (B1) and insert plate (B3).
Align the plate to the hole



8
Connect bracket (B1) to chassis using bolt (G),
spring washer (H) and hex bolt (I)

19



9
Middle left bracket (C1+C3):
Place bracket on chassis

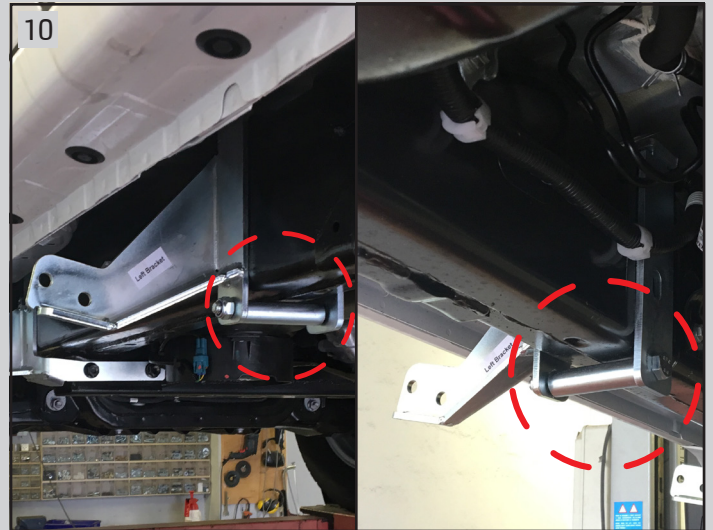

10
Connect bracket (C1+C3) to chassis using spacer (F).
Tighten bolt (I) and hex nut (J) to the bracket through
spacer

19



11
Rear left bracket (D1):
Remove the cap



12
Connect bracket (D1+D3) to chassis using hex bolt (J)
washer (G) and hex nut (I)

13

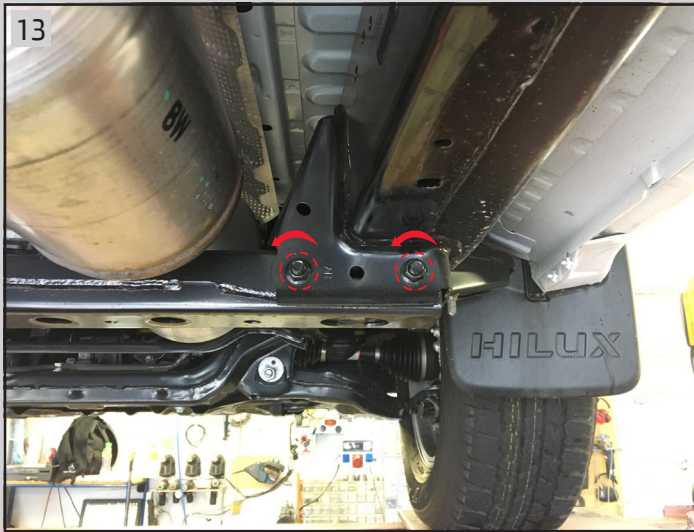

13
Front right bracket (B2):
Open 2 original nuts

17



14
Install bracket (B2) with the original nuts

17



15
Bend Plate (B4)

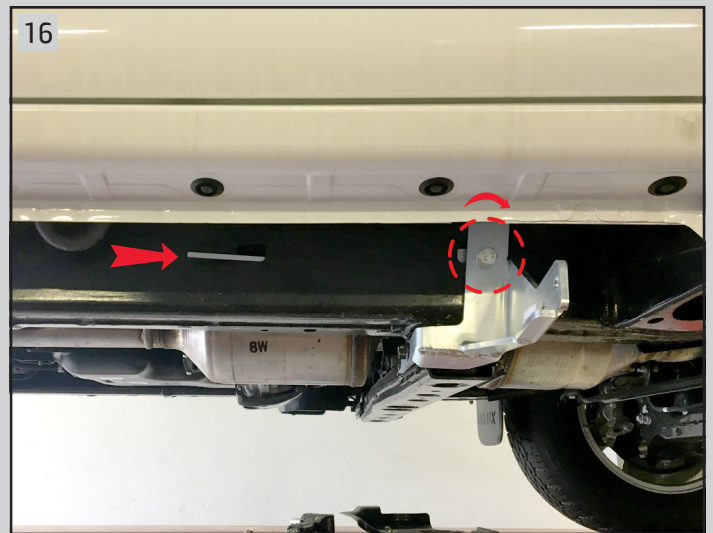

16
Insert plate (B4) through the chassis and align it to the hole. Close hex bolt (G), spring washer (H) and hex bolt (I) to the plate

13

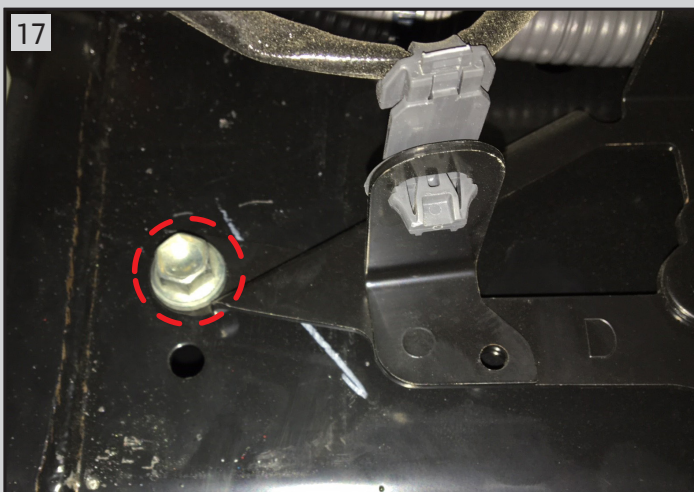

17
Middle right bracket (C2):
Remove original bolt



12



18
Connect bracket (C2+C4) to chassis using original bolt.
Insert spacer (F) and tighten bolt (I) and hex nut (J)

12

19



19
Rear right bracket:
Remove the cap on chassis outer side

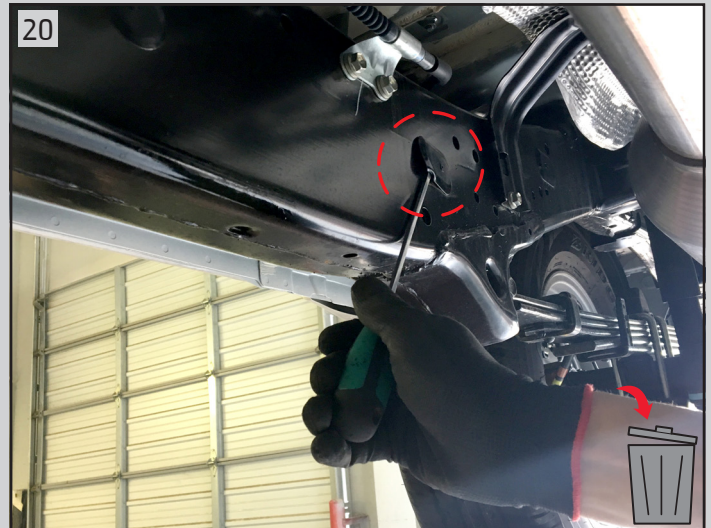
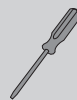

20
Remove the cap on chassis inner side



21
Place bracket (D2+D4) on chassis



22
Connect bracket (D2+D4) to chassis using hex bolt (E),
spring washer (H) and washer (G)



23
Tighten bolt



19



24
Place right and left steps (A1+A2) on the brackets and
place hex bolts (I), hex nut (J) and washer (G)



25
Make sure with a leveler that the steps are straight and parallel to the bottom line of the vehicle doors. Make sure the steps are horizontal in all dimensions



27
Connect steps to the brackets using 6 bolts (I), hex nut (J) and washer (G) on right side

19



26
Connect steps to the brackets using 6 hex bolts (I), hex nut (J) and washer (G) on left side

19

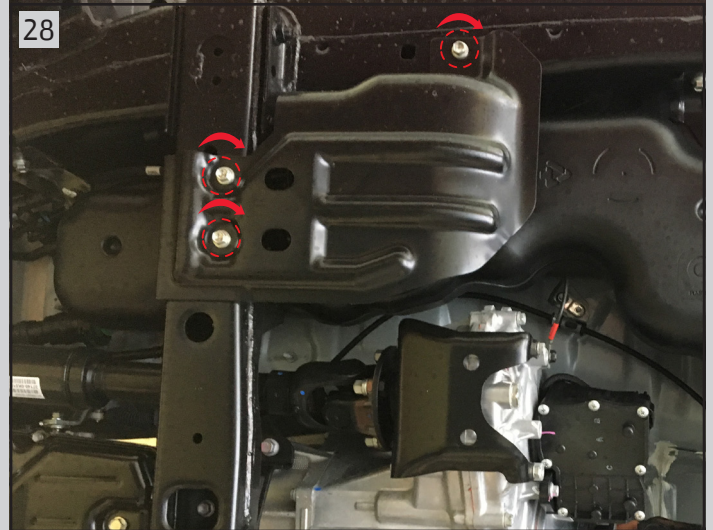

28
Reassemble Urea Tank Skid Plate and tighten 3 Bolts

12