

Confidential

All rights in and to this document are property of ASFIR Ltd. and reserved to it. This document is forwarded to the recipient under the condition of and subject to the obligation of the recipient to keep the confidentiality of its contents. Copying, transfer of distribution of this document or its contents and the use of it not for the purpose intended are strictly forbidden.

Maximum Tightening Torques

M12 (8.8) 85 Nm

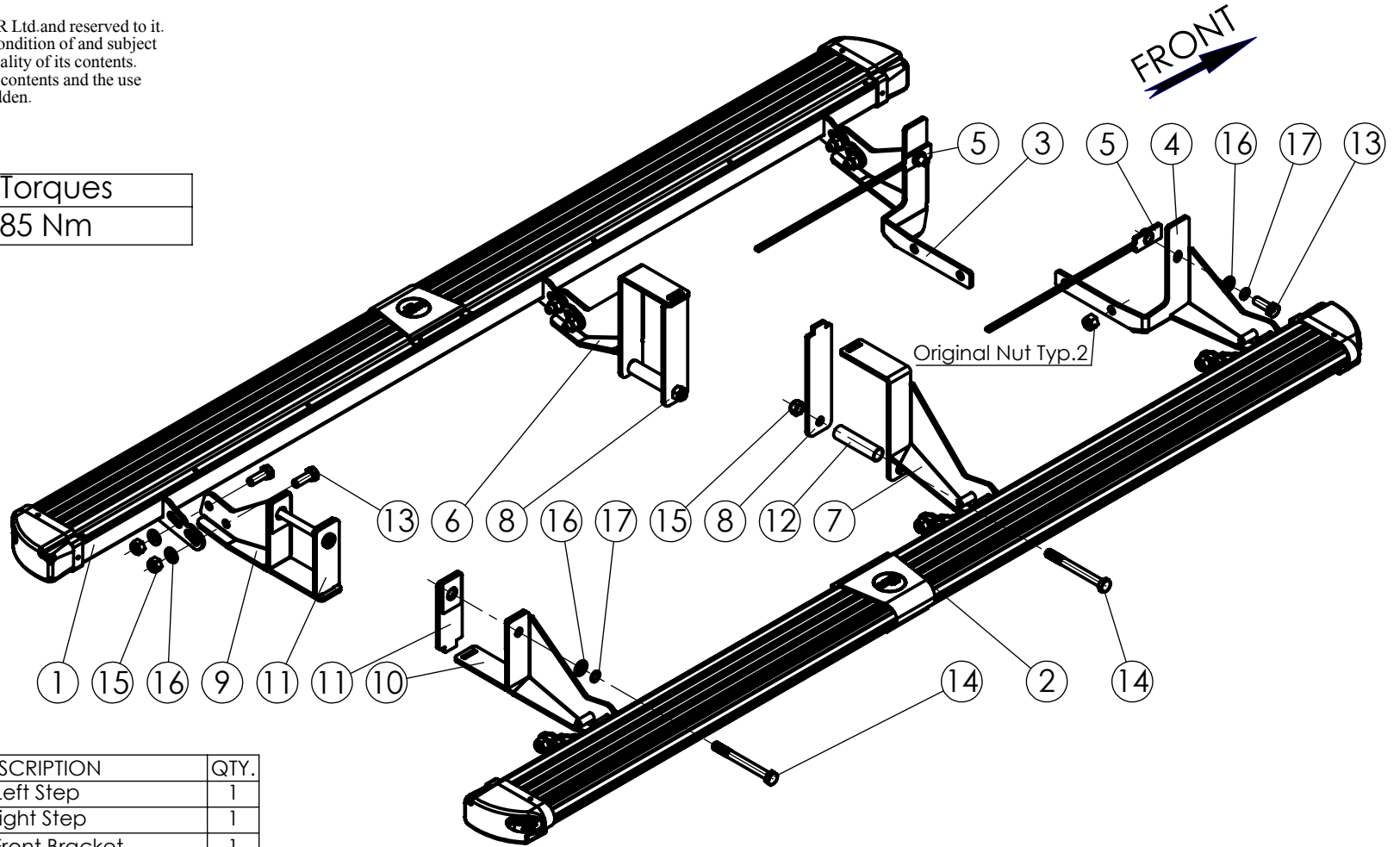

NO.	PART NUMBER	DESCRIPTION	QTY.
1	TYM103.100.000	Left Step	1
2	TYM103.100.000 R	Right Step	1
3	TYM103.000.001	Left Front Bracket	1
4	TYM103.000.004	Right Front bracket	1
5	TYM103.000.009	Plate for closing bolt	2
6	TYM103.000.002	Middle Left bracket	1
7	TYM103.000.005	Middle Right bracket	1
8	TYM103.000.003	Middle counter plate	2
9	TYM103.000.030	Left Rear bracket	1
10	TYM103.000.040	Right Rear bracket	1
11	TYM103.000.010	Rear counter plate	2
12	8553	Spacer 1/2" L=86 mm	2
13	1003	Hex Bolt M12x1.75x35 DIN 933	14
14	1013	Hex Bolt M12x1.75x120 DIN 931	4
15	3001	Hex Nut Nylock M12x1.75 DIN 985	14
16	6006	Washer 12x24 DIN 125	16
17	6005	Spring washer 12 DIN 127	4

				Drawing number	Product Description		
CHG.	Charnay	SIGN.	DATE	TYM103.000.000B	Vehicle Manufacturer	Toyota	
DWN.	Charnay		09.06.16		Vehicle Model	Hilux	
PLN.	David		20.10.15	Drawing description Side Step Protector Black	Vehicle Version	Double cab	
CONFIRM	Dani				Vin	MROHB3CD00400281	
ASFIR LTD.				Catalogue number	Year of Production	2016	
					533251	Gear Shift	Automatic/Manual
				Weight,kg	34	Motor Model	Diesel 2.4L Turbo
		Sheet	Sheets	1	Transmission	4 x 4	