

Gear and Transfer skid plate

Mounting instructions

for Toyota Hilux 2016-18

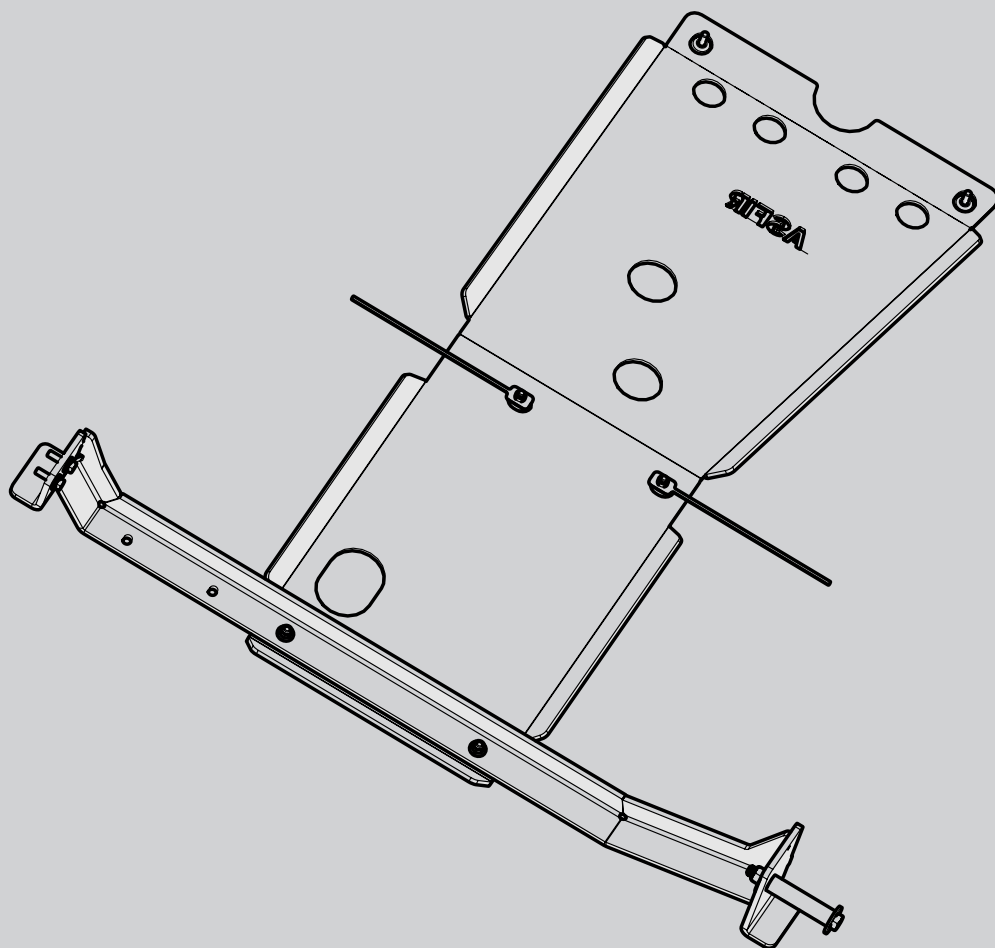

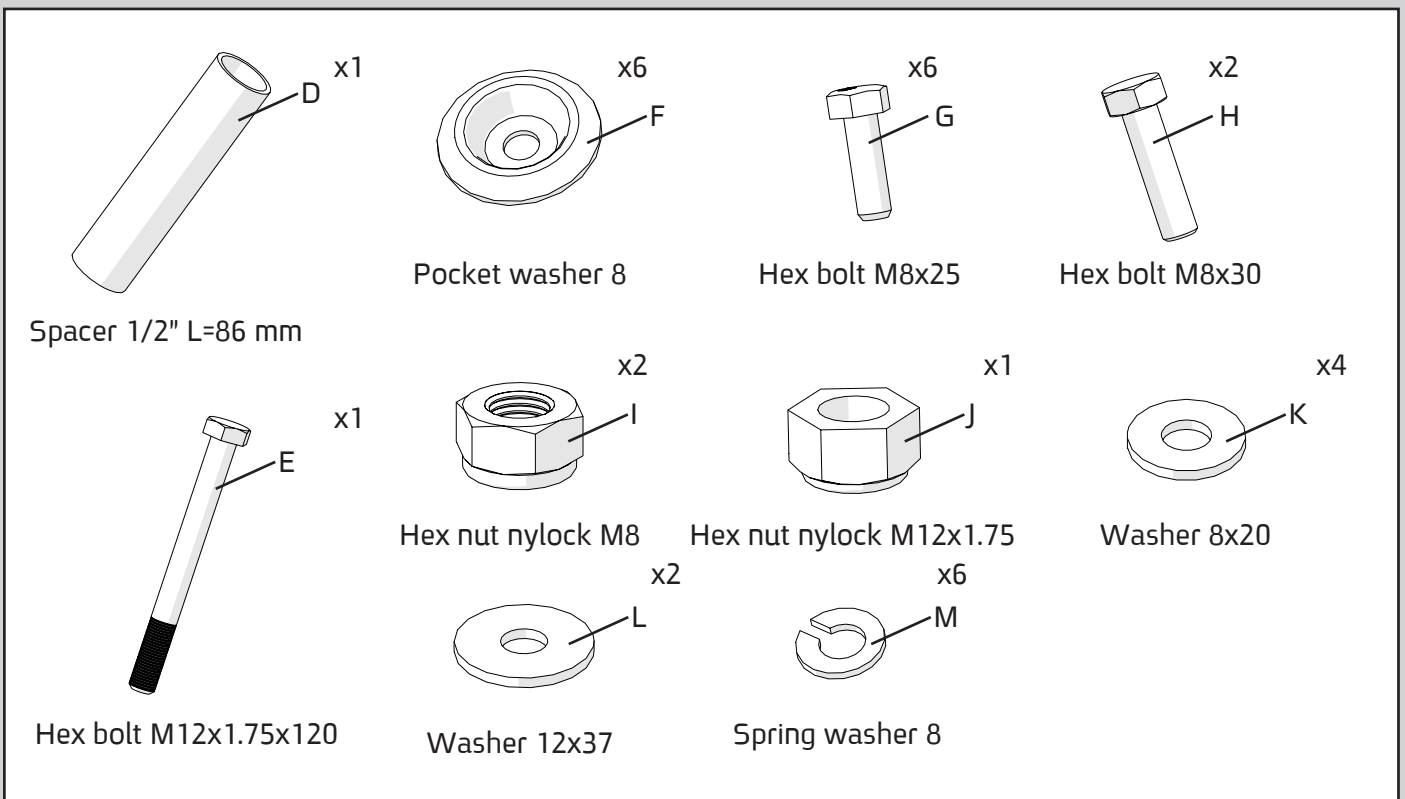
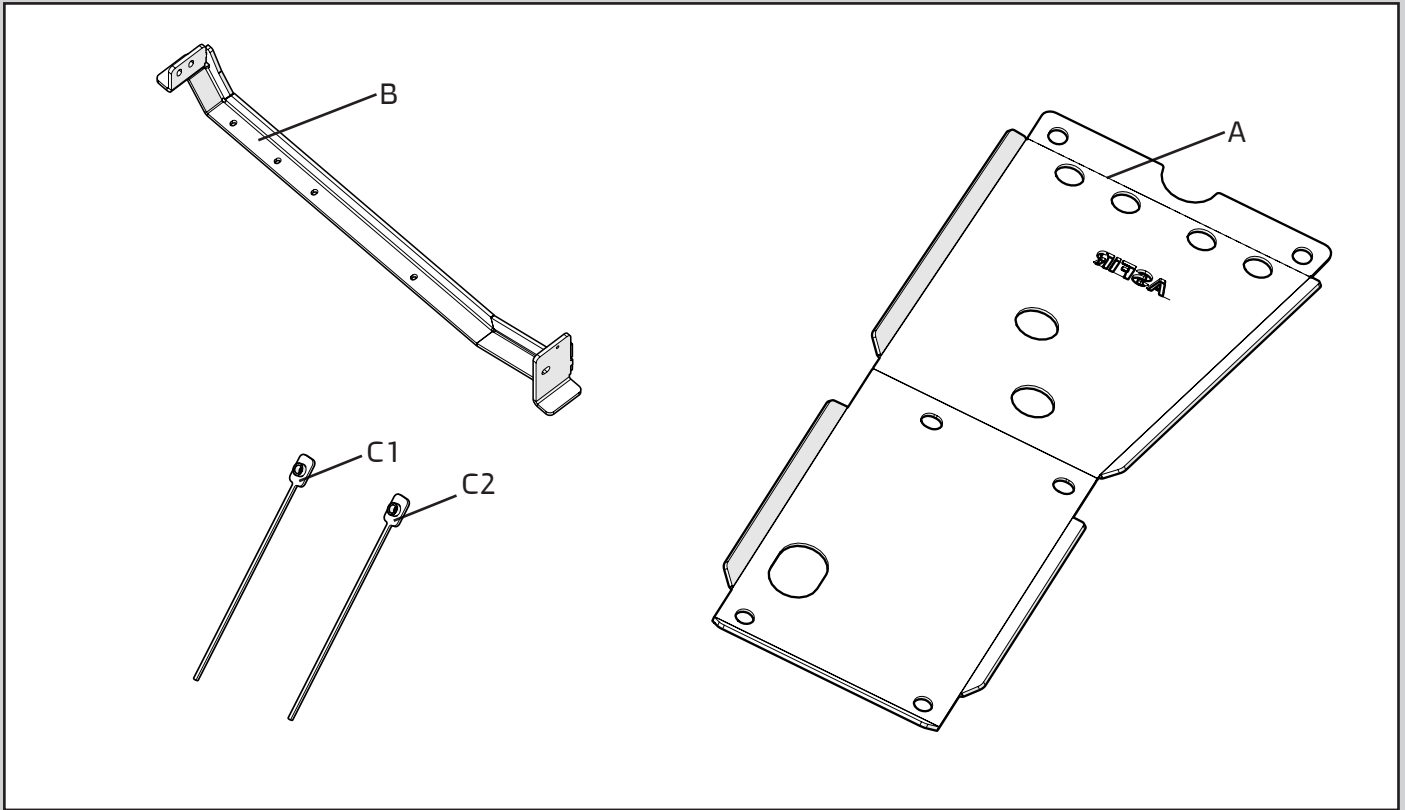

Maximum Tightening Torques	
M8 (8.8)	25 Nm
M12 (8.8)	85 Nm

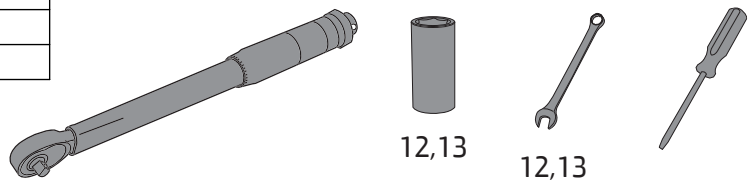

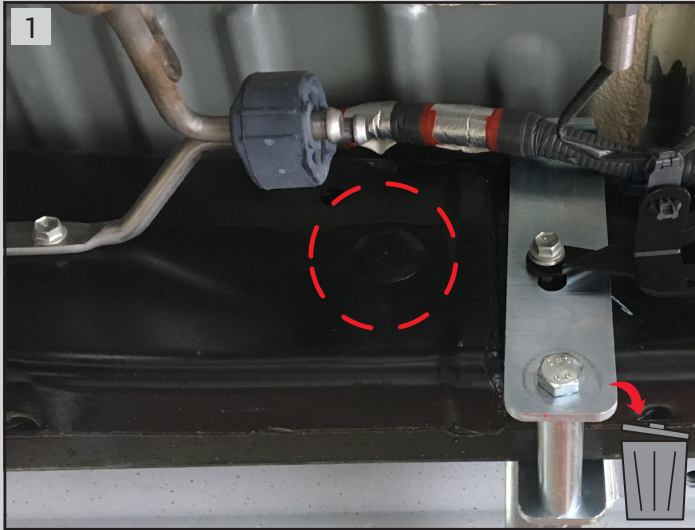

1 Right side of vehicle: Remove the cap from chassis inner side

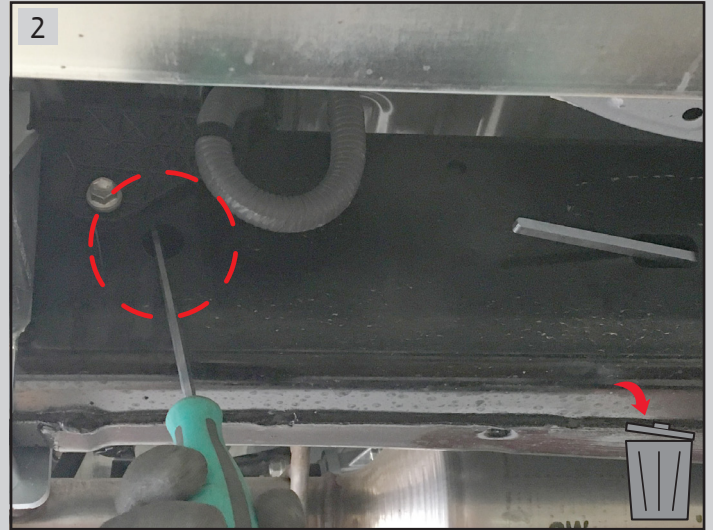

2 Remove the cap from chassis outer side

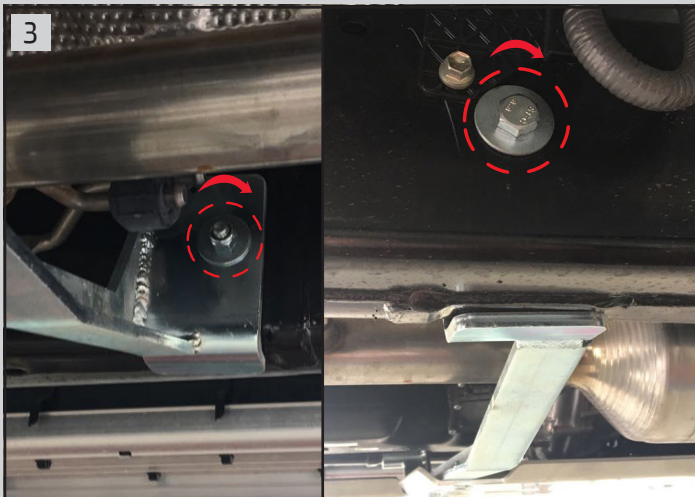

3 Place bracket (B). On right side of vehicle Insert spacer (D) through chassis and tighten the bolt (E) and washer (L) into the chassis outer side. Use hex nut (J) and washer (L) to connect the bracket to the chassis and spacer (D)



4 Connect bracket (B) left side to the chassis using bolt (H), spring washer (M) and washer (K). Right bolt - dont tighten it yet, leave for after placing the skid plate



5 Bend 2 Plates (C1+C2)



6 Insert plate (C1)



Insert plate (C2)

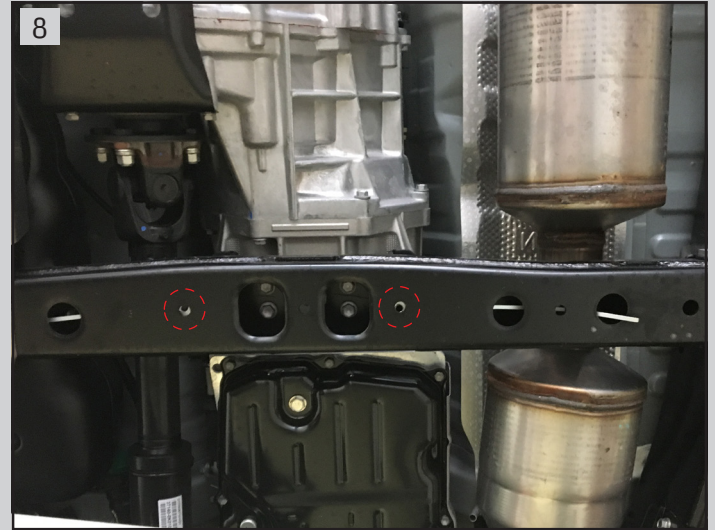

Align the plates (C1+C2) to the holes

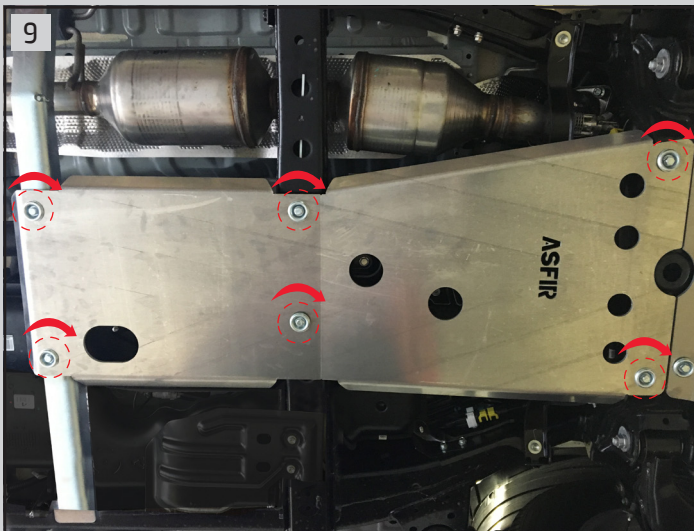

On the front: connect plate (A) to chassis using 2 hex bolts (G) spring washer (M) and pocket washer (F) to the original screwing

On the center: connect plate (A) to chassis using 2 hex bolts (G), spring washer (M) and pocket washer (F) into plates (C1+C2).

On the rear: connect plate (A) to the bracket using 2 hex bolts (G), pocket washer (F), washer (K) and hex nut (I). Tighten all bolts.

13



Tighten Right bolt (H)

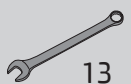

13