

NO.	PART NUMBER	DESCRIPTION	QTY.
1	TYM55.100.000	LEFT STEP	1
2	TYM55.100.000R	RIGHT STEP	1
3	TYM61.000.001L	Front Left Bracket	1
4	TYM61.000.001R	FRONT RIGHT BRACKET	1
5	TYM61.000.002	SPACER NUT M12x1.75	2
6	TYM55.000.001L	Left Bracket	1
7	TYM55.000.001R	RIGHT BRACKET	1
8	TYM55.000.002	Middle Right Connect	1
9	TYM55.020.000	Middle Left Connect	1
10	TYM55.030.000L	Rear Left Bracket	1
11	TYM55.030.000R	REAR RIGHT BRACKET	1
12	TYM21.040.000L	Rear Left Connect	1
13	TYM21.040.000R	REAR RIGHT CONNECT	1
14	8520	SPACER 1/2" L=93	2
15	1000	Hex bolt M8x35 DIN 933	6
16	1012	Hex bolt M12x1.75x30 DIN 933	12
17	1004	Hex bolt M12x1.75x40 DIN 933	2
18	1013	Hex bolt M12x1.75x120 DIN 931	6
19	1014	Hex bolt M12x1.75x130 DIN 931	2
20	3001	Hex Nut Nylock M12x1.75 DIN 985	18
21	6003	Washer 8x20 DIN 125	6
22	6006	Washer 12x24 DIN125	41
23	6001	Spring washer 8 DIN 127	6
24	6005	Spring washer 12 DIN 127	4

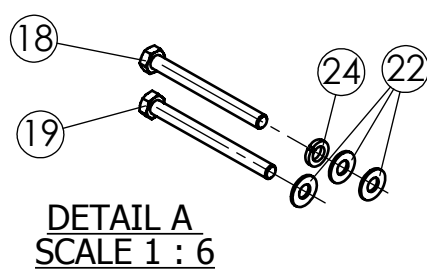
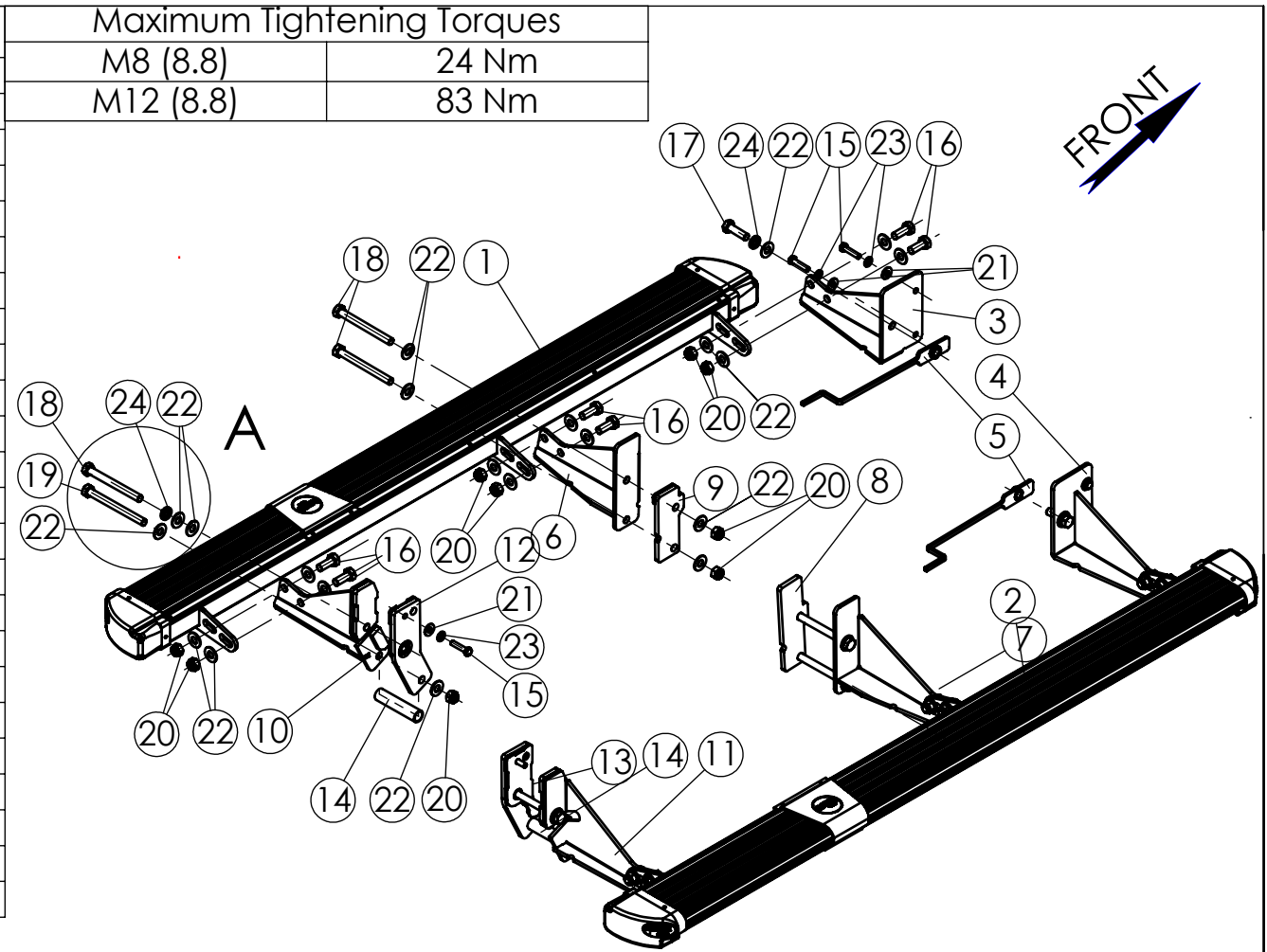

NAME	SIGN.	DATE	Drawing number	Product Description	
CHG. Charnay		07.01.16	TYM61.000.000B	Vehicle Manuf.	TOYOTA
DWN. Charnay		07.07.10		Vehicle Model	LAND CRUISER PRADO
PLN. David	<i>David 10/16</i>		Drawing description	Vehicle Version	GRJ150L-GKAEYW - LUXURY
CONFIRM Dani			Side Step Protector Black	VIN	JTEBH3FJ00K016665
ASFIR LTD.			Catalogue number	Year of Product.	2010-2015
			534153	Gear Shift	AUTOMATIC
			Weight,kg 31	Motor Model	PETROL / DIESEL
				Transmission	4X4

Confidential

All rights in and to this document are property of ASFIR Ltd. and reserved to it. This document is forwarded to the recipient under the condition of and subject to the obligation of the recipient to keep the confidentiality of its contents. Copying, transfer or distribution of this document or its contents and the use of it not for the purpose intended-are strictly forbidden.