

NO.	PART NUMBER	DESCRIPTION	QTY.
1	TYM76.100.000	Left Step	1
2	TYM76.100.000R	Right Step	1
3	TYM76.030.000	Front Left Bracket	1
4	TYM76.040.000	Front Right Bracket	1
5	TYM76.000.001	Middle Left Bracket	1
6	TYM76.000.002	Middle Right Bracket	1
7	TYM76.000.003	Rear Left Bracket	1
8	TYM76.000.004	Rear Right Bracket	1
9	TYM76.000.005	Middle Flat	2
10	TYM76.000.006	Rear Flat	2
11	8563	SPACER 1/2" L=65	3
12	8562	SPACER 1/2" L=74	1
13	1002	Hex bolt M8x40 DIN 933	2
14	1012	Hex bolt M12x1.75x30 DIN 933	12
15	1028	Hex bolt M12x1.75x100 DIN931	6
16	1013	Hex bolt M12x1.75x120 DIN 931	2
17	3001	Hex nut nylock M12x1.75 DIN 985	20
18	6003	Washer 8x21 DIN 125	2
19	6006	Washer 12x27 DIN125	16
20	6001	Spring washer 8 DIN127	2

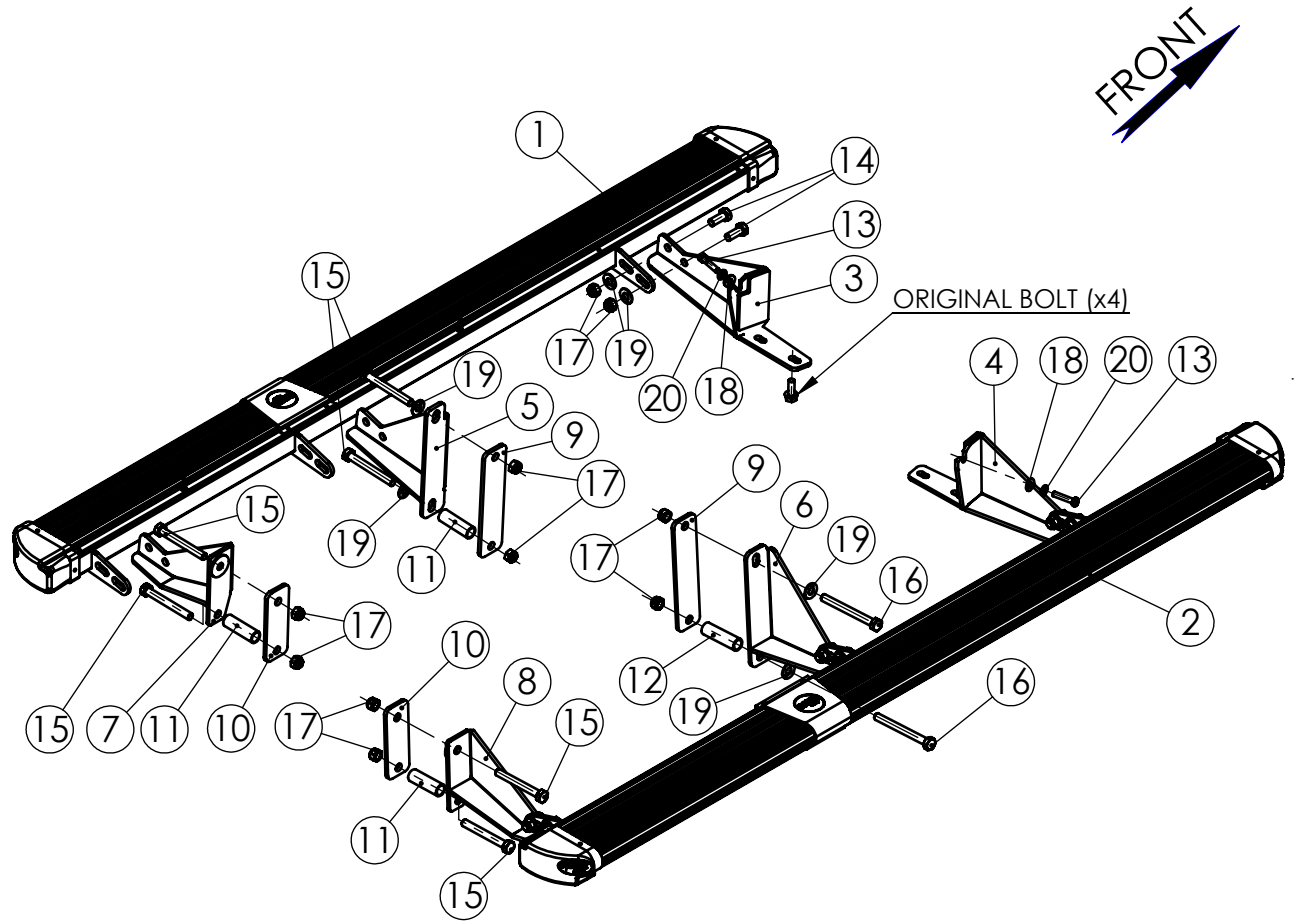

### Maximum Tightening Torques

M8 (8.8)	24 Nm
M12 (8.8)	83 Nm

#### Confidential

All rights in and to this document are property of ASFIR Ltd. and reserved to it. This document is forwarded to the recipient under the condition of and subject to the obligation of the recipient to keep the confidentiality of its contents. Copying, transfer or distribution of this document or its contents and the use of it not for the purpose intended-are strictly forbidden.

NAME	SIGN.	DATE	Drawing number	Product Description	
CHG.	Charnay	14.03.11	TYM76.000.000	Vehicle Manuf.	TOYOTA
PLN.	David	28.11.10		Vehicle Model	LAND CRUISER 100
DWN.	Charnay	28.11.10	Drawing description	Vehicle Version	SUV
CONFIRM	Dani		Side Step Protector	VIN	
<b>ASFIR LTD.</b>			Catalogue number	Year of Product.	1998-2008
			558054	Gear Shift	AUTOMATIC
			Weight,kg 32.0	Motor Model	DIESEL
				Transmission	4X4